

TRISTAR 3G



BREVETTO
Unical
PATENT

smoke pipes

PRESSURIZED CARBON STEEL BOILER WITH THREE REAL SMOKE PASS

OUTPUT RANGE

from 65 to 3000 kW

OPERATION TEMPERATURE

minimum return temperature 50°C

SUPPLY

Natural Gas or LPG fed pressure jet, two stage or modulating burners
The models 2300 - 2650 - 3000 can be fed also with light oil

MODELS

65 ^{2S}	85 ^{2S}	110 ^{2S}	150 ^{2S}	185 ^{2S}	225 ^{2S}	300 ^{2S}	380 ^{2S}	500 ^{2S}	630 ^{2S}
730 ^{2S}	840 ^{2S}	1100 ^{2S}	1320 ^{2S}	1600 ^{2S}	1900 ^{2S}	-	2300	2650	3000

ENERGETIC CLASS
according to Dir. 92/42/EC

★★★★CE

Certified in OUTPUT RANGE
Special patented smoke pipes with aluminium profiles – Floating furnace

MAIN COMPONENTS

Mod. 65÷1900

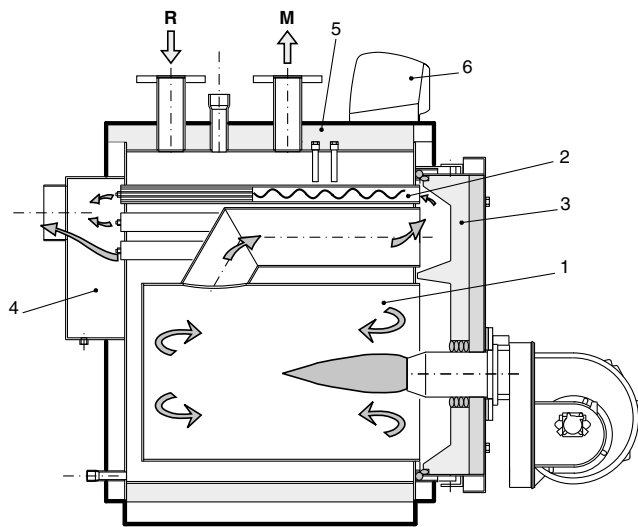

Mod. 2300÷3000

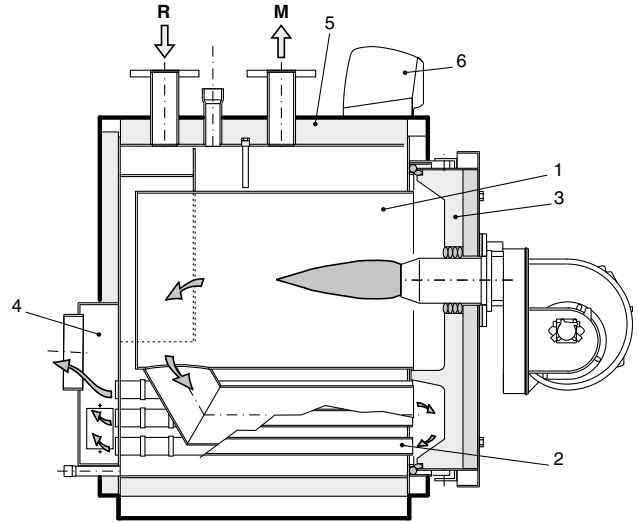

- 1. Furnace
- 2. Smoke pipes with smoke diverters
- 3. Door with flame sight glass
- 4. Smoke chamber
- 5. Body insulation
- 6. Panel board

TECHNICAL DATA

MODEL	Heat output	Heat input	Efficiency at	Efficiency at	Boiler capacity	Water side pressure drops	Flue gas pressure drops	Max. boiler operating pressure	Flue gas temperature	Combustion chamber	Weight
	min/max	min/max	full load (100%)	part load (30%)							
	kW	kW	%	%	l	m w.c.	mm w.c.	bar	°C	m ³	kg
TST 3G 65 2S	55÷65	58.2÷69.2	94.4÷93.9	94.6÷94.1	131	0.04÷0.06	4.6÷6.4	6	85÷100	0.060	315
TST 3G 85 2S	72÷85	76.1÷90.3	94.6÷94.1	94.8÷94.3	187	0.05÷0.07	5.4÷7.5	6	84÷99	0.088	355
TST 3G 110 2S	93÷109	98.1÷115.6	94.8÷94.3	95÷94.5	204	0.06÷0.08	7÷9.7	6	83÷98	0.130	435
TST 3G 150 2S	127÷150	133.6÷158.6	95÷94.5	95.2÷94.5	270	0.08÷0.10	11.2÷15.6	6	82÷97	0.139	515
TST 3G 185 2S	157÷185	164.9÷195.3	95.2÷94.7	95.2÷94.7	285	0.10÷0.18	14÷19.4	6	80÷95	0.155	580
TST 3G 225 2S	191÷225	200.2÷237.1	95.4÷94.9	95.4÷94.9	322	0.17÷0.20	16.6÷23.1	6	76÷91	0.176	640
TST 3G 300 2S	255÷300	265.9÷314.4	95.9÷95.4	95.6÷95.1	408	0.22÷0.35	20.5÷28.4	6	75÷90	0.239	840
TST 3G 380 2S	323÷380	336.8÷398.3	95.9÷95.4	96.1÷95.6	475	0.32÷0.53	23.6÷32.7	6	75÷90	0.280	935
TST 3G 500 2S	425÷500	443.1÷524.1	95.9÷95.4	96.1÷95.6	656	0.10÷0.15	27.3÷37.8	6	75÷90	0.389	1260
TST 3G 630 2S	535÷630	557.8÷660.3	95.9÷95.4	96.1÷95.6	737	0.16÷0.23	33.5÷46.5	6	75÷90	0.443	1375
TST 3G 730 2S	620÷730	646.5÷765.2	95.9÷95.4	96.1÷95.6	807	0.23÷0.33	37.5÷52	6	75÷90	0.498	1510
TST 3G 840 2S	714÷840	744.5÷880.5	95.9÷95.4	96.1÷95.6	932	0.35÷0.52	41.4÷57.3	6	75÷90	0.542	1650
TST 3G 1100 2S	935÷1100	974.9÷1153	95.9÷95.4	96.1÷95.6	1580	0.15÷0.21	48.8÷67.5	6	75÷90	0.753	2530
TST 3G 1320 2S	1122÷1320	1169.9÷1383.6	95.9÷95.4	96.1÷95.6	1791	0.21÷0.30	53.7÷74.3	6	75÷90	0.889	3065
TST 3G 1600 2S	1360÷1600	1418.1÷1677.1	95.9÷95.4	96.1÷95.6	2297	0.20÷0.28	58.9÷81.6	6	75÷90	1.116	4005
TST 3G 1900 2S	1615÷1900	1684÷1991.5	95.9÷95.4	96.1÷95.6	2496	0.27÷0.39	63.6÷88.1	6	75÷90	1.261	4230
TST 3G 2300	1725÷2300	1798.7÷2410.8	95.9÷95.4	96.1÷95.6	2875	0.20÷0.35	45÷80	6	75÷90	1.558	5350
TST 3G 2650	1987.5÷2650	2072.4÷2777.7	95.9÷95.4	96.1÷95.6	4320	0.19÷0.33	41.3÷73.5	6	75÷90	1.796	7070
TST 3G 3000	2250÷3000	2346.1÷3144.5	95.9÷95.4	96.1÷95.6	4817	0.26÷0.45	50.6÷90	6	75÷90	2.037	7600

On special order the boilers from model TRISTAR 3G 2S 1100 to TRISTAR 3G 3000 can be manufactured for a max. working pressure up to 10 bar.

PRODUCT PLUS VALUES



- **UTILISATION FLEXIBILITY**
thanks to the certification in ranged output
- **REDUCED NO_x EMISSIONS: < 100 mg/kWh**
thanks to the reduction of the specific thermal load
- **ELLIPTIC SHAPE OF THE OUTER SHELL**
(up to mod. 840 kW): reduced width making easier access through the doors
- **OTTIMIZZAZIONE SCAMBIO TERMICO**
through driven and braked run of the water within the boiler
- **SMOKE PIPES EASY STREAM PIPE Ø 1"1/2**
- **FLOATING CYLINDRICAL FURNACE** without thermomechanical stresses from 500 kW to 3000 kW
- **FURNACE BOTTOM**
with stiffening and heat dissipating plates
- **FRONT DOOR**
with self centering closing system
- **INSIDE DOOR INSULATION**
in special ceramic fibre up to 300 kW and in refractory concrete over 300 kW
- **HELICOIDAL STEEL TURBOLATORS**
- **BOILER BODY INSULATION** with a 80 mm thick tearing resistant mineral wool mattress up to 85 kW and 100 mm over 85 kW
- **CONTROL PANEL BOARD**
of thermomechanical or electronic type
- **POSSIBLE INSTALLATION**
of one/two/three stage or modulating oil or gas pressure jet burners
- **EASY HANDLING**
thanks to the upper hooks and the strong I profiles of the base

DIMENSIONS TRISTAR 3G 2S 65÷85

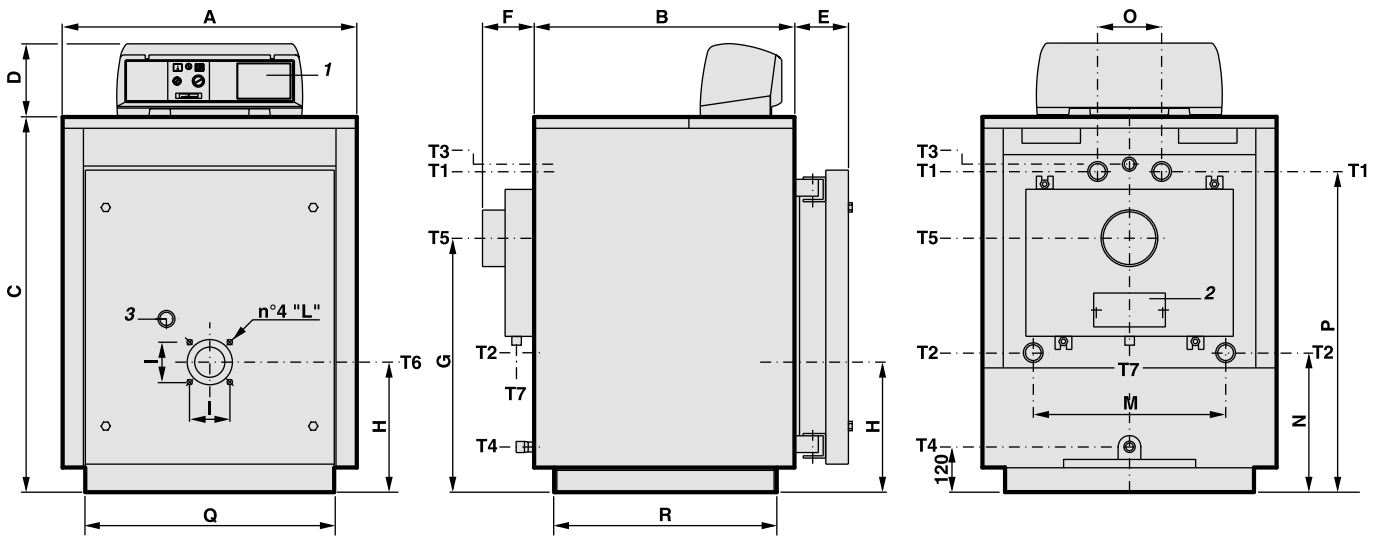

- 1 Panel board
- 2 Smoke chamber cleaning door
- 3 Flame sight glass

- T1 Central Heating flow
- T2 Central Heating return
- T3 Expansion vessel connection
- T4 Boiler drain

- T5 Chimney connection
- T6 Burner connection
- T7 Condensation drain

TRISTAR 3G 2S	Nominal output kW	Nominal input kW	Boiler capacity l	Water pressure drops(**) m w.c.	Flue gas pressure drop mm w.c.	Maximum boiler working pressure bar	Weight kg	CONNECTIONS					
								T1 T2	T3	T4	T5 Øi	T6 Ø	T7 Øe
65	55÷65	58.2÷69.2	131	0.04÷0.06	4.6÷6.4	6	315	Rp 1½	Rp 1	Rp ¾	150	132	40
85	72÷85	76.1÷90.3	187	0.05÷0.07	5.4÷7.5	6	355	Rp 1½	Rp 1	Rp ¾	150	132	40

TRISTAR 3G 2S	A	B	C	D	E	F	G	H	I	L	M	N	O	P	Q*	R*
	mm	mm	mm	mm	mm	mm	mm	mm	mm	mm	mm	mm	mm	mm	mm	mm
65	740	690	950	190	140	145	660	345	120	M8	470	310	190	846	660	590
85	740	950	950	190	140	145	660	345	120	M8	470	310	190	846	660	850

(*) Minimum dimensions for boiler room access. (**) Pressure drops corresponding to a thermal drop of 15K.

DIMENSIONS TRISTAR 3G 2S 110÷380

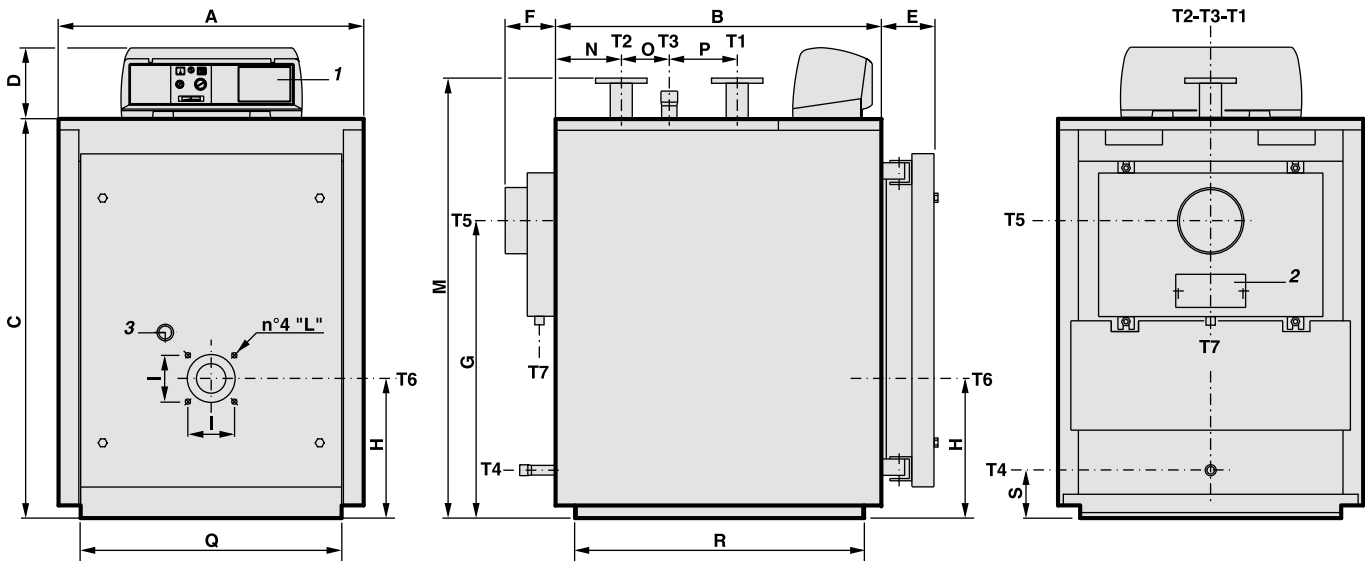

- 1 Panel board
- 2 Smoke chamber cleaning door
- 3 Flame sight glass
- T1 Central Heating flow
- T2 Central Heating return
- T3 Expansion vessel connection
- T4 Boiler drain
- T5 Chimney connection
- T6 Burner connection
- T7 Condensation drain

TRISTAR 3G 2S	Nominal output kW	Nominal input kW	Boiler capacity l	Water pressure drops(**) m w.c.	Flue gas pressure drop mm w.c.	Maximum boiler working pressure bar	Weight kg	CONNECTIONS					
								T1 T2	T3	T4	T5 Øi	T6 Ø	T7 Øe
								UNI 2278 PN16	ISO 7/1	ISO 7/1	mm	mm	mm
110	93÷109	98.1÷115.6	204	0.06÷0.08	7÷9.7	6	435	DN 50	Rp 1¼	Rp ¾	180	132	40
150	127÷150	133.6÷158.6	270	0.08÷0.10	11.2÷15.6	6	515	DN 50	Rp 1¼	Rp ¾	180	132	40
185	157÷185	164.9÷195.3	285	0.10÷0.18	14÷19.4	6	580	DN 65	Rp 1½	Rp ¾	180	180	40
225	191÷225	200.2÷237.1	322	0.17÷0.20	16.6÷23.1	6	640	DN 65	Rp 1½	Rp ¾	180	180	40
300	255÷300	265.9÷314.4	408	0.22÷0.35	20.5÷28.4	6	840	DN 80	Rp 2	Rp ¾	225	180	40
380	323÷380	336.8÷398.3	475	0.32÷0.53	23.6÷32.7	6	935	DN 80	Rp 2	Rp ¾	225	180	40

TRISTAR 3G 2S	A	B	C	D	E	F	G	H	I	L	M*	N	O	P	Q*	R*	S
	mm	mm	mm	mm	mm	mm	mm	mm	mm	mm	mm	mm	mm	mm	mm	mm	mm
110	820	885	1082	190	140	145	748	380	120	M 8	1210	175	130	185	710	786	130
150	820	1145	1082	190	140	145	748	380	120	M 8	1210	175	390	185	710	1046	130
185	860	1080	1182	190	140	145	828	400	--	--	1310	215	210	250	750	981	130
225	860	1210	1182	190	140	145	828	400	--	--	1310	215	340	250	750	1111	130
300	890	1275	1352	190	140	145	928	440	--	--	1485	255	285	315	780	1177	125
380	890	1470	1352	190	140	145	928	440	--	--	1485	255	480	315	780	1372	125

(*) Minimum dimensions for boiler room access.
 (**) Pressure drops corresponding to a thermal drop of 15K.

DIMENSIONS TRISTAR 3G 2S 500÷730 - 840

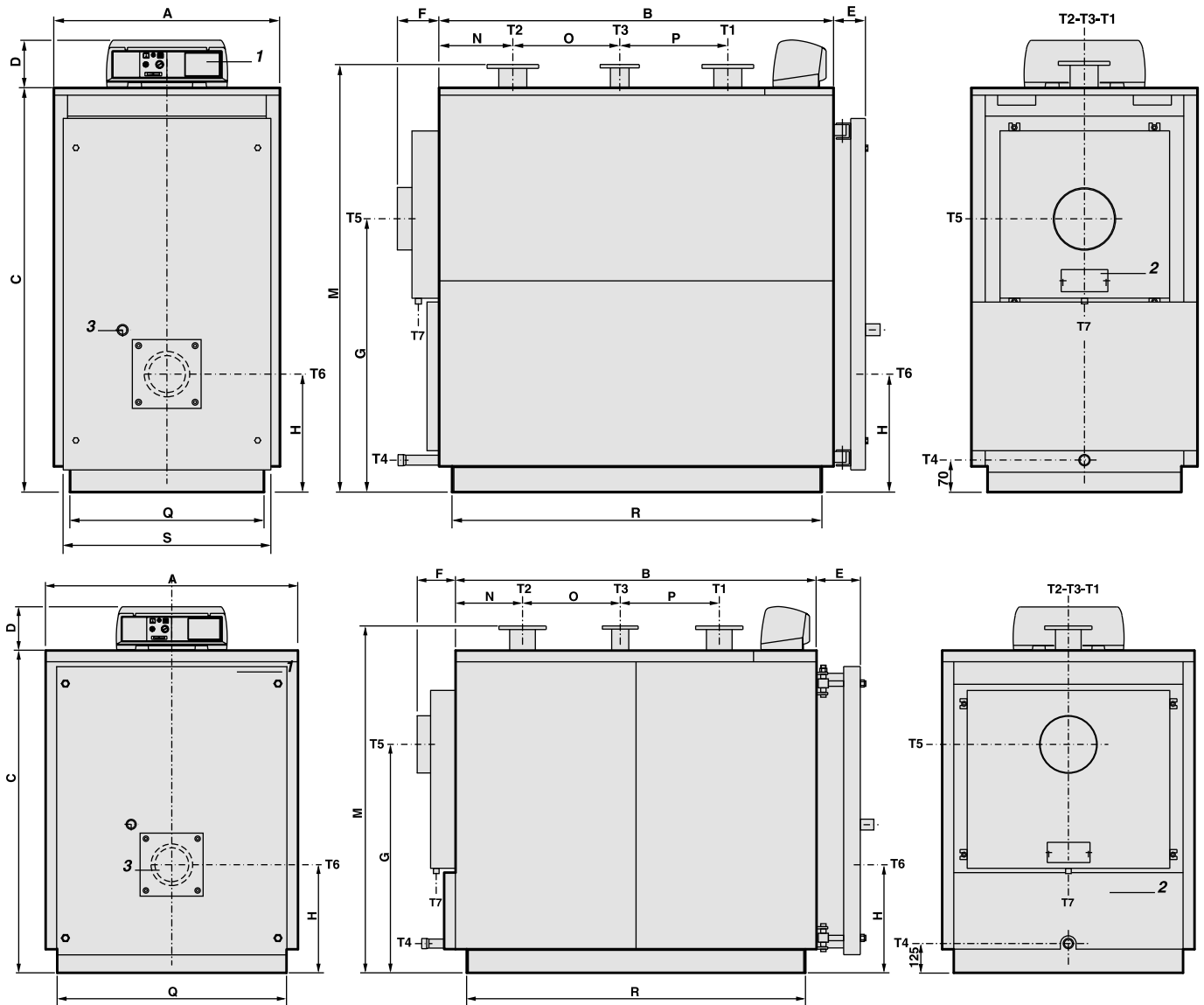

- 1 Panel board
- 2 Smoke chamber cleaning door
- 3 Flame sight glass
- T1 Central Heating flow
- T2 Central Heating return
- T3 Expansion vessel connection
- T4 Boiler drain
- T5 Chimney connection
- T6 Burner connection
- T7 Condensation drain

TRISTAR 3G 2S	Nominal output	Nominal input	Boiler capacity	Water pressure drops(**)	Flue gas pressure drop	Maximum boiler working pressure	Weight	CONNECTIONS					
								T1 T2	T3	T4	T5 Øi	T6 Ø	T7 Øe
	kW	kW	l	m w.c.	mm w.c.	bar	kg	UNI 2278 PN16	UNI 2278 PN16	ISO 7/1	mm	mm	mm
500	425÷500	443.1÷524.1	656	0.10÷0.15	27.3÷37.8	6	1260	DN 100	DN 65	Rp 1	250	220	40
630	535÷630	557.8÷660.3	737	0.16÷0.23	33.5÷46.5	6	1375	DN 100	DN 65	Rp 1	250	220	40
730	620÷730	646.5÷765.2	807	0.23÷0.33	37.5÷52	6	1510	DN 100	DN 65	Rp 1	250	220	40
840	714÷840	744.5÷880.5	932	0.35÷0.52	41.4÷57.3	6	1650	DN 100	DN 65	Rp 1¼	250	270	40

TRISTAR 3G 2S	A	B	C	D	E	F	G	H	M*	N	O	P	Q*	R*	S*
	mm	mm	mm	mm	mm	mm	mm	mm	mm	mm	mm	mm	mm	mm	mm
500	920	1605	1645	190	135	195	1110	480	1735	298	435	440	790	1505	860
630	920	1800	1645	190	135	195	1110	480	1735	298	630	440	790	1790	860
730	920	1995	1645	190	135	195	1110	480	1735	298	825	440	790	1895	860
840	1122	2115	1432	190	195	195	1025	480	1540	298	945	440	1020	2014	--

(*) Minimum dimensions for boiler room access.
 (**) Pressure drops corresponding to a thermal drop of 15K.

DIMENSIONS TRISTAR 3G 2S 1100÷1900

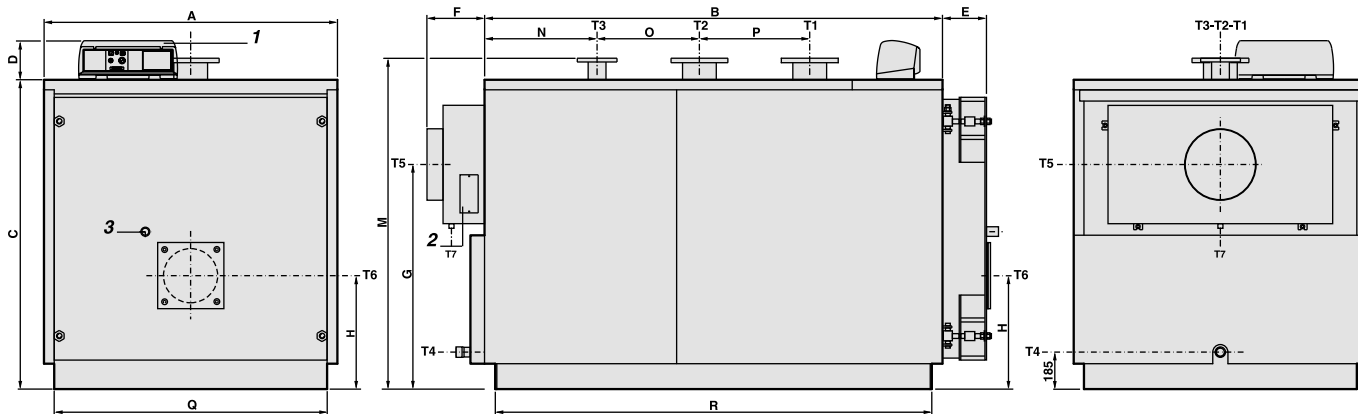

- 1 Panel board
- 2 Smoke chamber cleaning door
- 3 Flame sight glass
- T1 Central Heating flow
- T2 Central Heating return
- T3 Expansion vessel connection
- T4 Boiler drain
- T5 Chimney connection
- T6 Burner connection
- T7 Condensation drain

TRISTAR 3G 2S	Nominal output kW	Nominal input kW	Boiler capacity l	Water pressure drops(**) m w.c.	Flue gas pressure drop mm w.c.	Maximum boiler working pressure bar	Weight kg	CONNECTIONS					
								T1 T2	T3	T4	T5 Øi	T6 Ø	T7 Øe
1100	935÷1100	974.9÷1153	1580	0.15÷0.21	48.8÷67.5	6	2530	UNI 2278 PN16 DN 150	UNI 2278 PN16 DN 80	ISO 7/1 Rp 1½	mm 350	mm 270	mm 40
1320	1122÷1320	1169.9÷1383.6	1791	0.21÷0.30	53.7÷74.3	6	3065	DN 150	DN 80	Rp 1½	350	270	40
1600	1360÷1600	1418.1÷1677.1	2297	0.20÷0.28	58.9÷81.6	6	4005	DN 175	DN 100	Rp 1½	400	285	40
1900	1615÷1900	1684÷1991.5	2496	0.27÷0.39	63.6÷88.1	6	4230	DN 175	DN 100	Rp 1½	400	285	40

TRISTAR 3G 2S	A	B	C	D	E	F	G	H	M*	N	O	P	Q*	R*
	mm	mm	mm	mm	mm	mm	mm	mm	mm	mm	mm	mm	mm	mm
1100	1462	2282	1542	190	230	290	1120	565	1650	561	510	550	1360	2176
1320	1462	2652	1542	190	230	290	1120	565	1650	561	880	550	1360	2546
1600	1622	2692	1702	190	260	290	1245	605	1810	661	670	700	1520	2590
1900	1622	3014	1702	190	260	290	1245	605	1810	662	990	700	1520	2910

(*) Minimum dimensions for boiler room access.

(**) Pressure drops corresponding to a thermal drop of 15K.

On special order the boilers from model 1100 to 3000 can be manufactured for a max. working pressure up to 10 bar.

DIMENSIONS TRISTAR 3G 2300÷3000

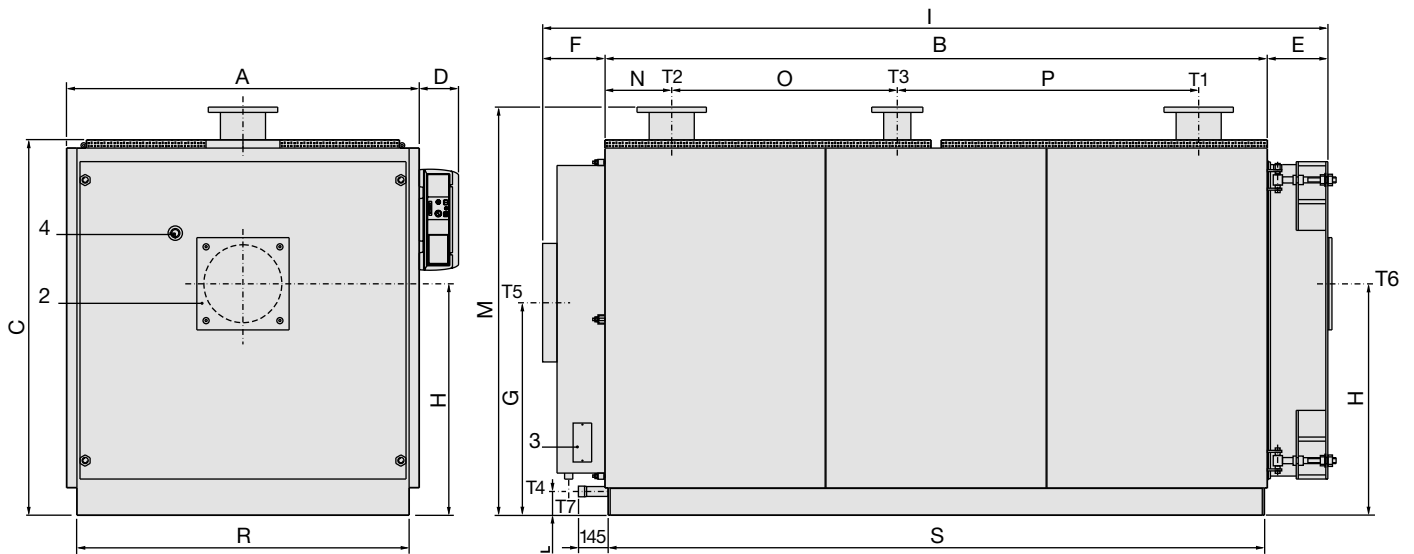

- 1 Panel board
- 2 Burner connection flange
- 3 Smoke chamber cleaning door
- 4 Flame control warning light
- T1 Heating flow
- T2 Heating return
- T3 Expansion vessel connection
- T4 Boiler drain
- T5 Chimney connection
- T6 Burner connection
- T7 Condensation drain

TRISTAR 3G	Nominal output kW	Nominal input kW	Boiler capacity l	Water pressure drops(**) m w.c.	Flue gas pressure drop mm w.c.	Maximum boiler working pressure bar	Weight kg	CONNECTIONS					
								T1 T2	T3	T4	T5 Øi	T6 Ø	T7 Øe
2300	1725÷2300	1798.7÷2410.8	2875	0.20÷0.35	45÷80	6	5350	UNI 2278 PN16 DN 200	UNI 2278 PN16 DN 125	ISO 7/1 Rp 1½	mm 570	mm 320	mm 40
2650	1987.5÷2650	2072.4÷2777.7	4320	0.19÷0.33	41.3÷73.5	6	7070	UNI 2278 PN16 DN 200	UNI 2278 PN16 DN 125	ISO 7/1 Rp 1½	mm 620	mm 380	mm 40
3000	2250÷3000	2346.1÷3144.5	4817	0.26÷0.45	50.6÷90	6	7600	UNI 2278 PN16 DN 200	UNI 2278 PN16 DN 125	ISO 7/1 Rp 1½	mm 620	mm 380	mm 40

TRISTAR 3G	A	B	C	D	E	F	G	H	I	L	M*	N	O	P	R*	S
	mm	mm	mm	mm	mm	mm	mm	mm	mm	mm	mm	mm	mm	mm	mm	mm
2300	1720	3230	1830	190	295	310	1315	1225	3835	115	1990	325	1100	1470	1620	3200
2650	1970	3194	2090	190	325	360	1535	1450	3879	144	2271	377	1060	1420	1870	3164
3000	1970	3594	2090	190	325	360	1535	1450	4279	144	2271	777	1060	1420	1870	3564

(*) Minimum dimensions for boiler room access.

(**) Pressure drops corresponding to a thermal drop of 15K.

On special order the boilers from model 1100 to 3000 can be manufactured for a max. working pressure up to 10 bar.

BURNER HEAD TUBE DIMENSIONS

BOILER TYPE	$\varnothing A$ mm	L mm
TRISTAR 3G 65÷85 2S	132	180
TRISTAR 3G 110÷150 2S	132	180
TRISTAR 3G 185÷225 2S	180	180
TRISTAR 3G 300÷380 2S	180	200
TRISTAR 3G 500÷730 2S	220	230
TRISTAR 3G 840 2S	270	280
TRISTAR 3G 1100÷1320 2S	270	320
TRISTAR 3G 1600÷1900 2S	285	350
TRISTAR 3G 2300 2S	320	350
TRISTAR 3G 2650÷3000 2S	380	400

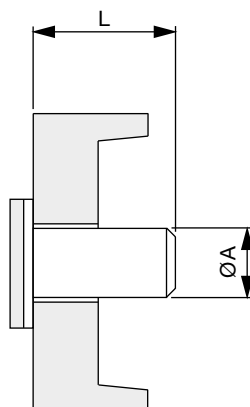

SPECIAL SMOKE PIPES (patented)

The pipes of the third smoke pass are decisive for the attainment of the **maximum efficiency**.

The new patented technology has allowed to insert special aluminium multi-fin structures inside the thick steel pipes. In this way are born the new "EASY STREAM Pipes" of 1 1/2" diameter.

BREVETTO
Unical
PATENT



TECHNICAL DATA

ELECTRICAL, HYDRAULIC, INSTALLATION DIAGRAMS AND CONTROLLERS can be unloaded from the web site www.unical.eu at the page of the product

Gas-fired		TST 3G 65 2S	TST 3G 85 2S	TST 3G 110 2S	TST 3G 150 2S	TST 3G 185 2S
Nominal heat output	kW	55÷65	72÷85	93÷109	127÷150	157÷185
Nominal heat input	kW	58.2÷69.2	76.1÷90.3	98.1÷115.6	133.6÷158.6	164.9÷195.3
Heat efficiency at nominal load (100%)	%	94.4÷93.9	94.6÷94.1	94.8÷94.3	95÷94.5	95.2÷94.7
Heat efficiency at 30% load	%	94.6÷94.1	94.8÷94.3	95÷94.5	95.2÷94.7	95.4÷94.9
Number of stars (according to ex 92/42 EEC)		3	3	3	3	3
Combustion efficiency at nominal load (100%)	%	95.9÷95.1	95.9÷95.2	96÷95.2	96÷95.3	96.1÷95.4
Heat loss at casing (min.- max.)	%	1.4÷1.2	1.3÷1.1	1.2÷0.9	0.9÷0.7	0.8÷0.6
Heat loss at chimney with burner on (min.-max.)	%	4.1÷4.9	4.1÷4.8	4÷4.8	4÷4.7	3.9÷4.6
Heat loss at chimney with burner off (min.-max.)	%	0.1÷0.1	0.1÷0.1	0.1÷0.1	0.1÷0.1	0.1÷0.1
Flue gas temperature tf-ta (min.-max.)	°C	85÷100	84÷99	83÷98	82÷97	80÷95
CO ₂ content	%	9.8÷9.8	9.8÷9.8	9.8÷9.8	9.8÷9.8	9.8÷9.8
Flue gas mass flow rate (min.-max)	kg/h	87.6÷104	114.5÷135.8	147.5÷173.8	200.8÷238.5	247.8÷293.5

Gas-fired		TST 3G 225 2S	TST 3G 300 2S	TST 3G 380 2S	TST 3G 500 2S	TST 3G 630 2S
Nominal heat output	kW	191÷225	255÷300	323÷380	425÷500	535÷630
Nominal heat input	kW	200.2÷237.1	265.9÷314.4	336.8÷398.3	443.1÷524.1	557.8÷660.3
Heat efficiency at nominal load (100%)	%	95.4÷94.9	95.9÷95.4	95.9÷95.4	95.9÷95.4	95.9÷95.4
Heat efficiency at 30% load	%	95.6÷95.1	96.1÷95.6	96.1÷95.6	96.1÷95.6	96.1÷95.6
Number of stars (according to ex 92/42 EEC)		3	3	3	--	--
Combustion efficiency at nominal load (100%)	%	96.3÷95.6	96.3÷95.6	96.3÷95.6	96.3÷95.6	96.3÷95.6
Heat loss at casing (min.- max.)	%	0.9÷0.7	0.4÷0.2	0.4÷0.2	0.4÷0.2	0.4÷0.2
Heat loss at chimney with burner on (min.-max.)	%	3.7÷4.4	3.7÷4.4	3.7÷4.4	3.7÷4.4	3.7÷4.4
Heat loss at chimney with burner off (min.-max.)	%	0.1÷0.1	0.1÷0.1	0.1÷0.1	0.1÷0.1	0.1÷0.1
Flue gas temperature tf-ta (min.-max.)	°C	76÷91	75÷90	75÷90	75÷90	75÷90
CO ₂ content	%	9.8÷9.8	9.8÷9.8	9.8÷9.8	9.8÷9.8	9.8÷9.8
Flue gas mass flow rate (min.-max)	kg/h	300.9÷356.4	399.7÷472.7	506.3÷598.7	666.1÷787.8	838.5÷992.6

Gas-fired		TST 3G 730 2S	TST 3G 840 2S	TST 3G 1100 2S	TST 3G 1320 2S	TST 3G 1600 2S
Nominal heat output	kW	620÷730	714÷840	935÷1100	1122÷1320	1360÷1600
Nominal heat input	kW	646.5÷765.2	744.5÷880.5	974.9÷1153	1169.9÷1383.6	1418.1÷1677.1
Heat efficiency at nominal load (100%)	%	95.9÷95.4	95.9÷95.4	95.9÷95.4	95.9÷95.4	95.9÷95.4
Heat efficiency at 30% load	%	96.1÷95.6	96.1÷95.6	96.1÷95.6	96.1÷95.6	96.1÷95.6
Number of stars (according to ex 92/42 EEC)		--	--	--	--	--
Combustion efficiency at nominal load (100%)	%	96.3÷95.6	96.3÷95.6	96.3÷95.6	96.3÷95.6	96.3÷95.6
Heat loss at casing (min.- max.)	%	0.4÷0.2	0.4÷0.2	0.4÷0.2	0.4÷0.2	0.4÷0.2
Heat loss at chimney with burner on (min.-max.)	%	3.7÷4.4	3.7÷4.4	3.7÷4.4	3.7÷4.4	3.7÷4.4
Heat loss at chimney with burner off (min.-max.)	%	0.1÷0.1	0.1÷0.1	0.1÷0.1	0.1÷0.1	0.1÷0.1
Flue gas temperature tf-ta (min.-max.)	°C	75÷90	75÷90	75÷90	75÷90	75÷90
CO ₂ content	%	9.8÷9.8	9.8÷9.8	9.8÷9.8	9.8÷9.8	9.8÷9.8
Flue gas mass flow rate (min.-max)	kg/h	971.7÷1150.2	1119.1÷1323.5	1465.5÷1733.1	1758.6÷2079.7	2131.6÷2520.9

Gas-fired		TST 3G 1900 2S	TST 3G 2300	TST 3G 2650	TST 3G 3000
Nominal heat output	kW	1615÷1900	1725÷2300	1987.5÷2650	2250÷3000
Nominal heat input	kW	1684÷1991.5	1798.7÷2410.8	2072.4÷2777.7	2346.1÷3144.5
Heat efficiency at nominal load (100%)	%	95.9÷95.4	95.9÷95.4	95.9÷95.4	95.9÷95.4
Heat efficiency at 30% load	%	96.1÷95.6	96.1÷95.6	96.1÷95.6	96.1÷95.6
Number of stars (according to ex 92/42 EEC)		--	--	--	--
Combustion efficiency at nominal load (100%)	%	96.3÷95.6	96.3÷95.6	96.3÷95.6	96.3÷95.6
Heat loss at casing (min.- max.)	%	0.4÷0.2	0.4÷0.2	0.4÷0.2	0.4÷0.2
Heat loss at chimney with burner on (min.-max.)	%	3.7÷4.4	3.7÷4.4	3.7÷4.4	3.7÷4.4
Heat loss at chimney with burner off (min.-max.)	%	0.1÷0.1	0.1÷0.1	0.1÷0.1	0.1÷0.1
Flue gas temperature tf-ta (min.-max.)	°C	75÷90	75÷90	75÷90	75÷90
CO ₂ content	%	9.8÷9.8	9.8÷9.8	9.8÷9.8	9.8÷9.8
Flue gas mass flow rate (min.-max)	kg/h	2531.3÷2993.5	2703.7÷3623.8	3115.1÷4175.2	3526.5÷4726.7